

Series	MG Series
Block Type	Standard
Model Size	9
Block	Standard Block
Preload Class	Light Clearance (4 ~ 10 μm)
Precision Code	C

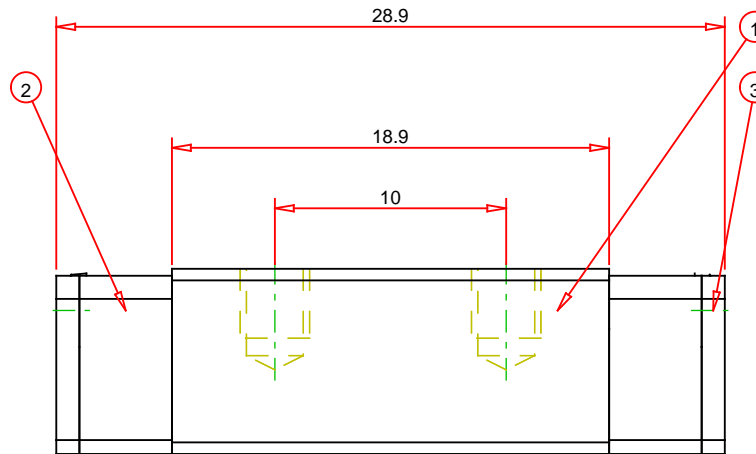
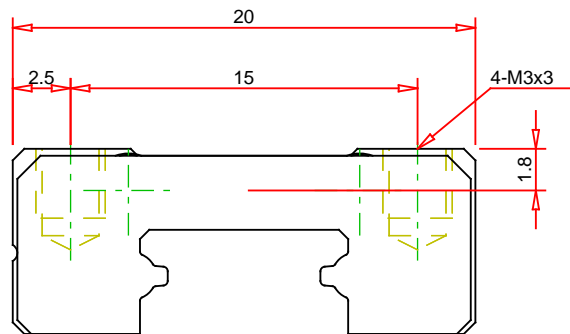

3	End Seal	2
2	End Cap	2
1	Block	1
No.	Part Name	Qty

Notes : - Drawing not to scale
- Dimensions subject to change without notice

Part No. :

MGN9CZFC

Description :

MG Series - Interchangeable Type - Block

HIWIN[®]
Motion Control and System Technology

Hiwin Technologies Corp.

Taiwan:
Address : No. 7, Jingke Road
Taichung Precision Machinery Park
Taichung 40852, Taiwan
Tel. : +886-4-23594510
Email : business@hiwin.tw
Web : www.hiwin.tw

Hiwin Corp.

USA:
Address : 12455 Jim Dhamer Dr
Huntley, IL 60142
Tel. : +1-847-827-2270
Email : info@hiwin.com
Web : www.hiwin.com